

M51320P

ANALOG SWITCH

DESCRIPTION

The M51320P is a semiconductor integrated circuit containing analog switches designed for use in a video system. It contains two audio switches and one video switch. One audio switch has two inputs and the other, three. The video switch has two inputs. Each switch can be independently controlled. In addition, the video switch contains an amplifier with a gain of about 6.7dB.

FEATURES

- Video and stereo sound switches in one package
- Wide frequency range(video switch).....DC~10MHz
- High separation(video).....Crosstalk 55dB(typ.)@5MHz

APPLICATION

Video equipment.

RECOMMENDED OPERATING CONDITION

Supply voltage range.....5 - 14V

PIN CONFIGURATION (TOP VIEW)

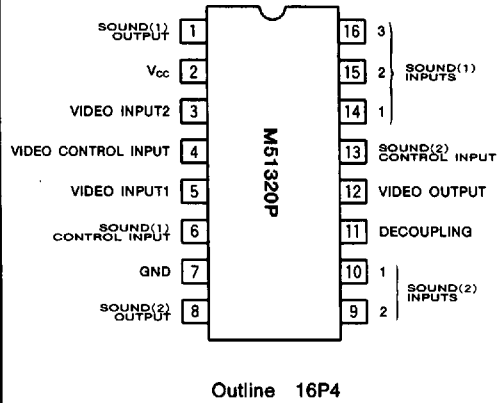

BLOCK DIAGRAM

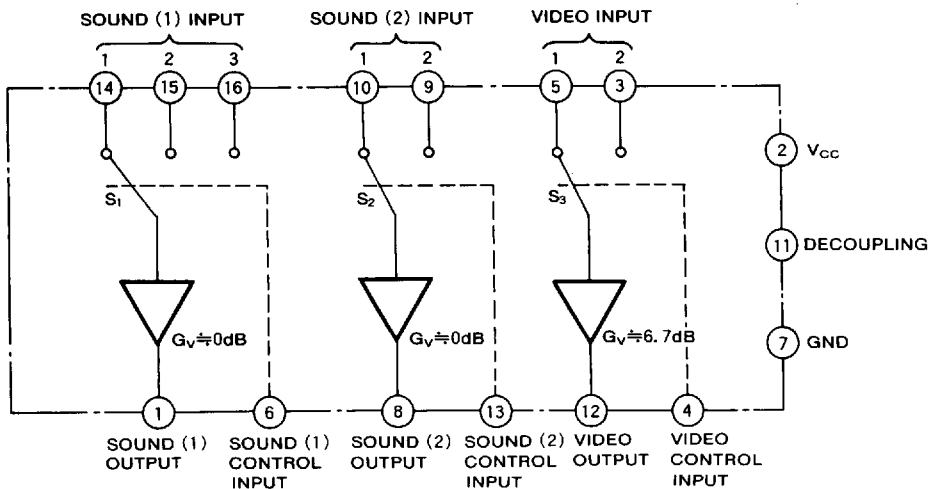

6249826 0021432 65T

ABSOLUTE MAXIMUM RATINGS

Symbol	Parameter	Rating	Unit
V _{CC}	Supply voltage	14	V
V _{IS}	Input signal voltage	6	V
		6	
V _{IC}	Input control voltage	V _{CC}	V
P _d	Power dissipation	1.25	W
K _θ	Thermal derating	12.5	mW/°C
T _{opr}	Operating temperature	-20~75	°C
T _{stg}	Storage temperature range	-40~125	°C

ELECTRICAL CHARACTERISTICS (T_a=25°C, V_{CC}=12V, unless otherwise noted)

Symbol	Parameter	Test conditions	Limits			Unit
			Min.	Typ.	Max.	
I _{CC}	Circuit current			40	50	mA
V _{IDC}	Input bias voltage		3.8	4.2	4.6	V
V _{ODC}	Output bias voltage	Video	5.0	5.6	6.2	V
		Sound	3.0	3.6	4.2	
V _{OP}	Output DC offset voltage			15	100	mV
V _{ICH}	Control-pin threshold voltage	Sound (1) (pin⑥ 3-state input)	7.0	8.0	9.0	V
V _{ICL}		Sound (1) (pin⑥ 3-state input)	3.0	4.0	5.0	V
V _{IC}		Sound (2) and video (pin④, ⑬)	1.7	2.1	2.5	V
G _V	Voltage gain	Video, f=1MHz, V _{IN} =1Vrms	5.7	6.7	8.2	dB
		Sound, f=1kHz, V _{out} =2Vrms	-0.5	-0.1		
THD	Total harmonic distortion	Sound, f=1kHz, V _{IN} =1Vrms		0.02	0.2	%
V _N	Output noise voltage	Sound, R _g =600Ω, BW=15kHz		3	50	μVrms
		Video, R _g =75Ω, BW=10MHz		0.5	1.0	mVrms
CT	Crosstalk	Sound, f=1kHz	65	80		dB
		Video, f=5MHz	45	55		

SWITCH MODE

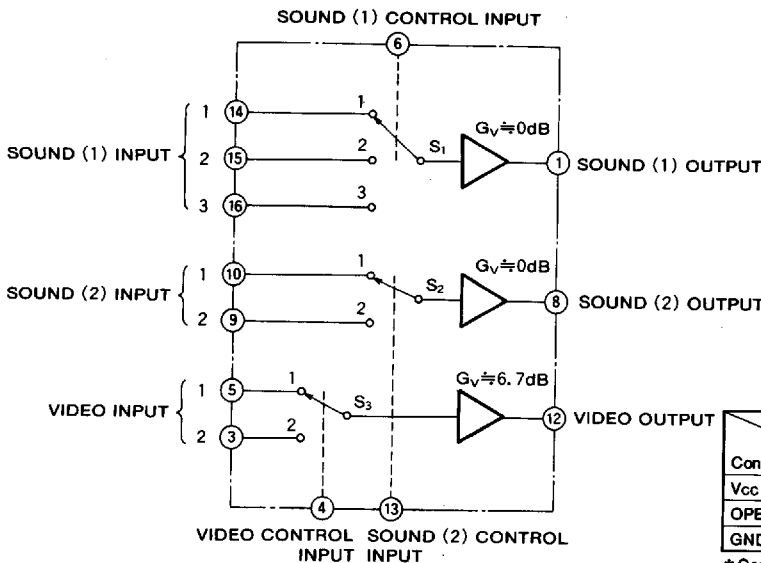

Control Input	Switch No.		
	S ₁	S ₂	S ₃
V _{CC}	1	1	1
OPEN	2	*	*
GND	3	2	2

* Connect to V_{CC} or GND

6249826 0021433 596

TEST CIRCUIT (Ta=25°C, Vcc=12V, unless otherwise noted)

CIRCUIT CURRENT I_{cc}, INPUT BIAS VOLTAGE V_{IDC}, OUTPUT BIAS VOLTAGE V_{OOC} TEST CIRCUIT

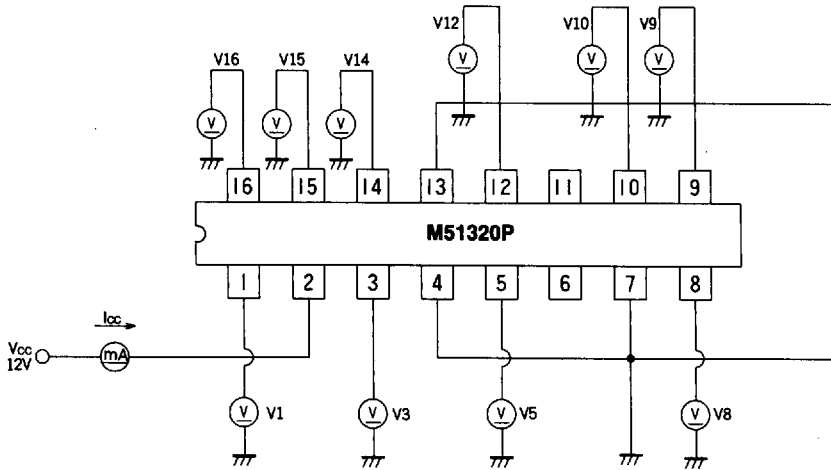

OUTPUT DC OFFSET VOLTAGE TEST CIRCUIT

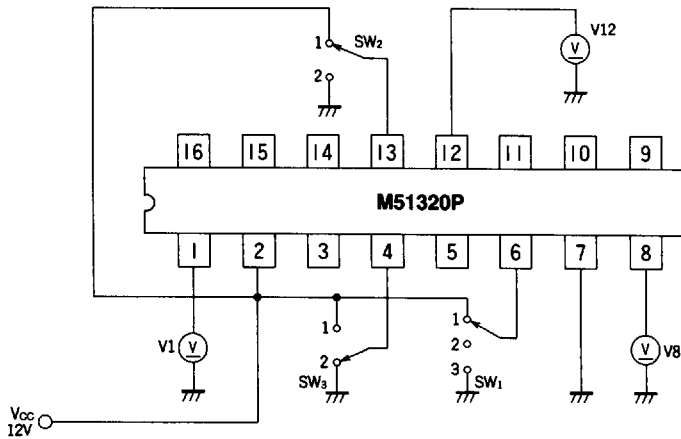

$\Delta V_{OOC} = V_{max} - V_{min}$

- Video : Measure each DC voltage of V12, when SW₃ is turned to 1 or 2, with SW₁ to 2 and SW₂ to 2.
- Sound (1) : Measure each DC voltage of V1, when SW₁ is turned to 1, 2, or 3, with SW₂ to 2 and SW₃ to 2.
- Sound (2) : Measure each DC voltage of V8, when SW₂ is turned to 1 or 2, with SW₁ to 2 and SW₃ to 2.

CONTROL PIN THRESHOLD VOLTAGE TEST CIRCUIT

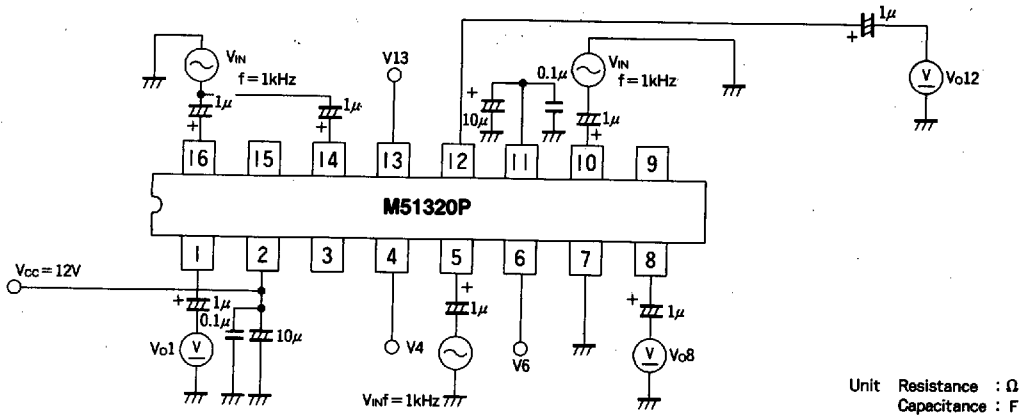

Sound (1) control pin threshold voltage test

V_{ICL} shows the value of V₆ when AC component of ① pin waveform is switched OFF after initially raising DC voltage V₆ to 3-5 V. V_{ICH} shows the value of V₆ when AC component is switched ON, after initially raising DC voltage V₆ to 7-9 V.

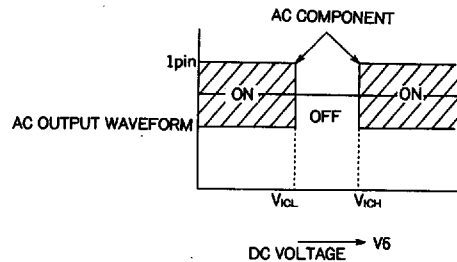

Sound (2) control pin threshold voltage test

V₁₃ shows the value of V_{IC} when the AC component of ③ pin waveform is switched ON, after initially raising DC voltage V₁₃ to 1-3 V.

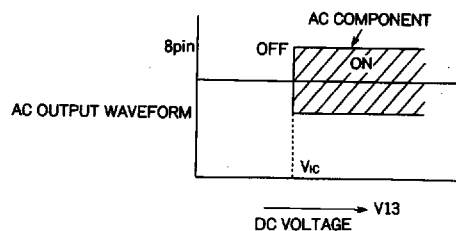

Video control pin threshold voltage test

V₄ shows the value of V_{IC} when AC component of ② pin waveform is switched ON, after initially raising the DC voltage V₄ to 1-3 V.

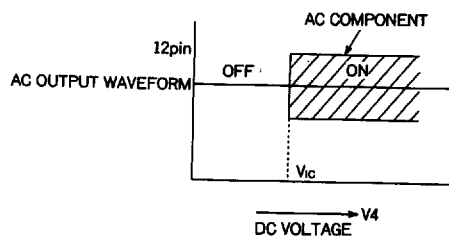

CROSSTALK AND TOTAL HARMONIC DISTORTION TEST CIRCUIT (SOUND SWITCH)

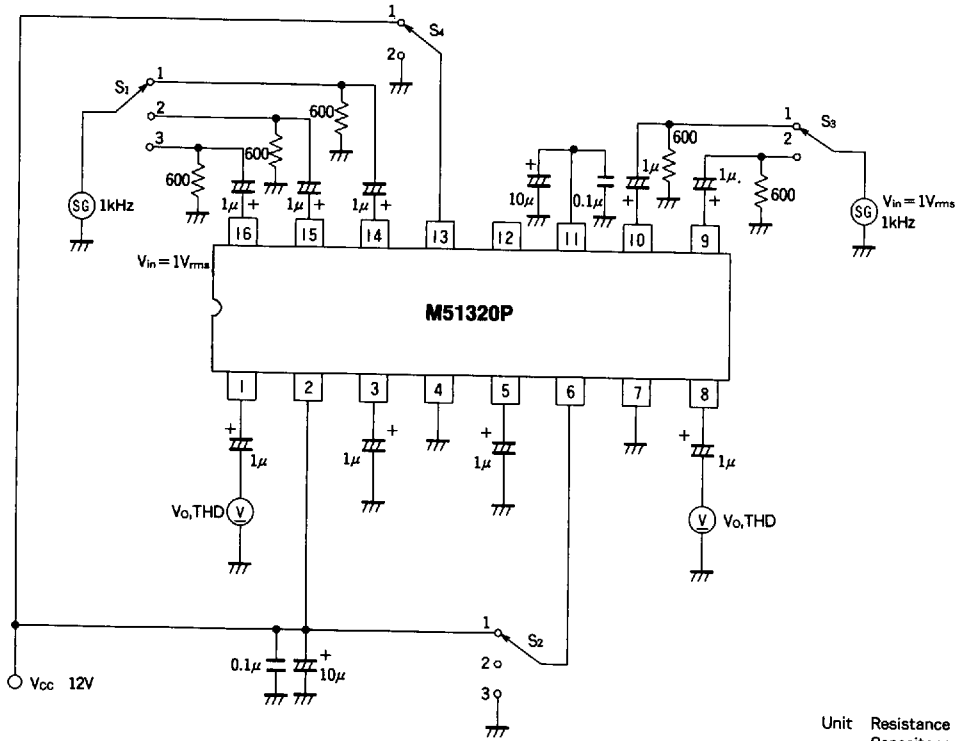

Unit Resistance : Ω
Capacitance : F

SWITCH MODE LIST

S ₁	S ₂	OUTPUT(①pin)
1	1	V _{os, THD}
	2, 3	V _{oc}
2	2	V _{os, THD}
	1, 3	V _{oc}
3	3	V _{os, THD}
	1, 2	V _{oc}

S ₃	S ₄	OUTPUT(⑧pin)
1	1	V _{os, THD}
	2	V _{oc}
2	1	V _{oc}
	2	V _{os, THD}

Crosstalk $CT = 20 \log \left(\frac{V_{os}}{V_{oc}} \right)$ dB

Voltage gain $GV = 20 \log \left(\frac{V_{os}}{V_{in}} \right)$ dB

CROSSTALK, VOLTAGE GAIN (VIDEO SWITCH)

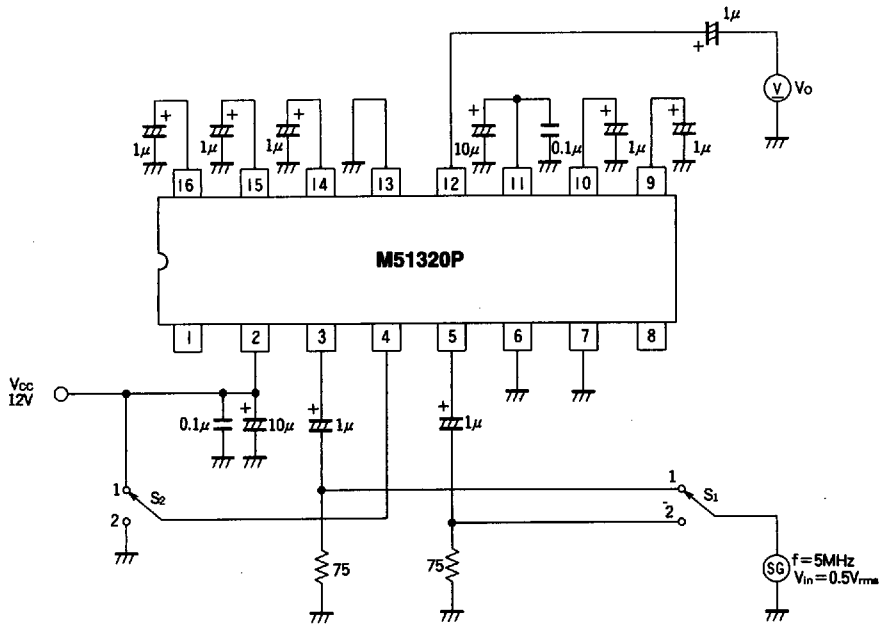

Unit Resistance : Ω
Capacitance : F

SWITCH MODE LIST

S ₁	S ₂	OUTPUT (⑩pin)
1	1	V _{oc}
	2	V _{os}
2	1	V _{os}
	2	V _{oc}

Crosstalk $CT = 20 \log \left(\frac{V_{os}}{V_{oc}} \right)$ dB

Voltage gain $GV = 20 \log \left(\frac{V_{os}}{V_{in}} \right)$ dB

OUTPUT NOISE VOLTAGE

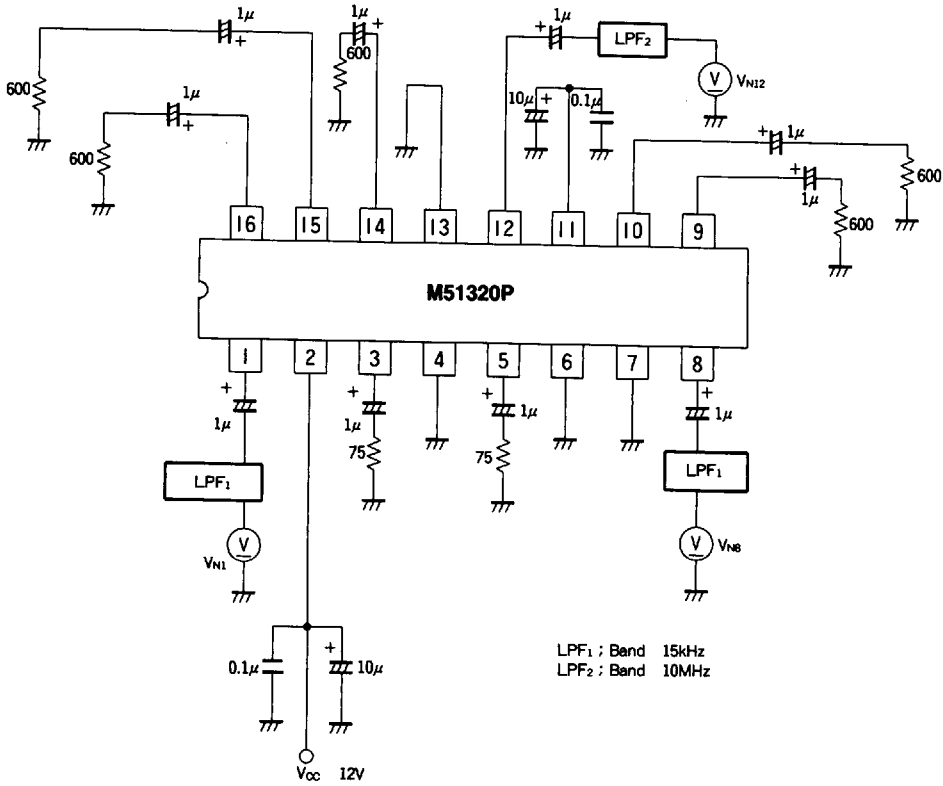

Unit Resistance : Ω
 Capacitance : F

TYPICAL CHARACTERISTICS (Ta=25°C, unless otherwise noted)

THERMAL DERATING (MAXIMUM RATING)

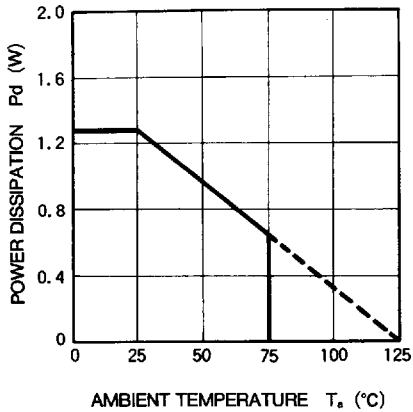

CIRCUIT CURRENT VS. SUPPLY VOLTAGE

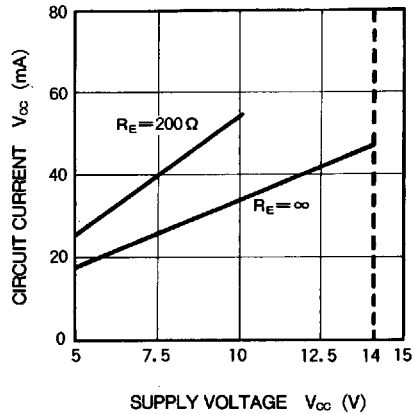

VOLTAGE GAIN VS. FREQUENCY (SOUND)

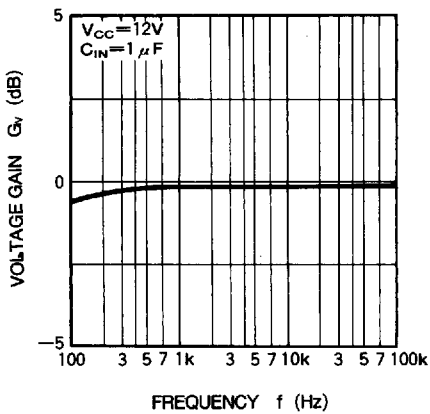

TOTAL HARMONIC DISTORTION VS. OUTPUT VOLTAGE (SOUND)

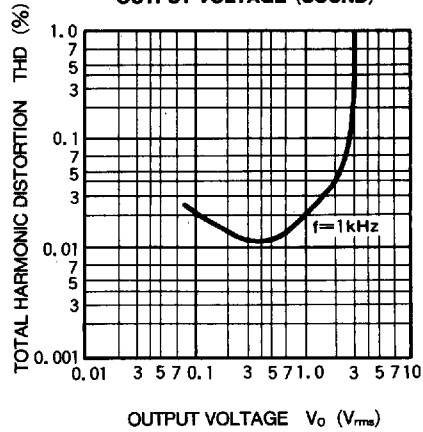

TOTAL HARMONIC DISTORTION VS. FREQUENCY (SOUND)

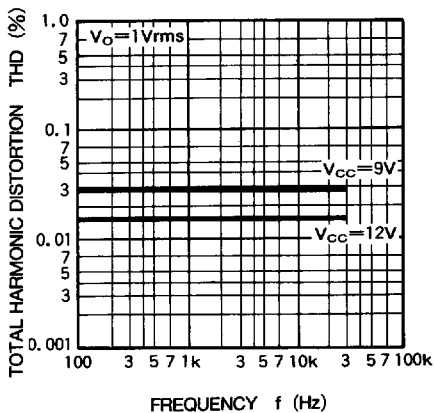

OUTPUT DC VOLTAGE VS. INPUT DC VOLTAGE (SOUND)

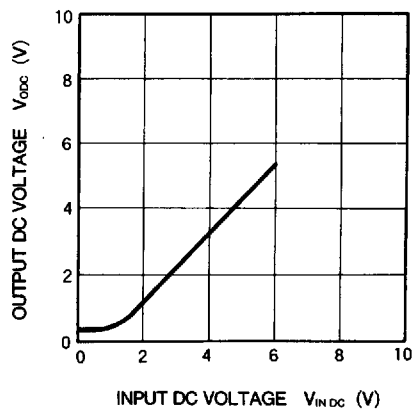

6249826 0021439 T04

CROSSTALK, VS. FREQUENCY (SOUND)

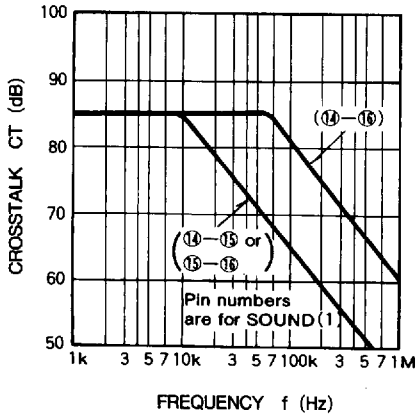

OUTPUT NOISE VOLTAGE VS. SIGNAL SOURCE RESISTANCE (SOUND)

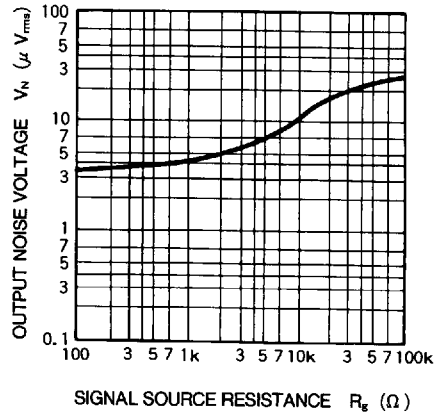

VOLTAGE GAIN VS. FREQUENCY (VIDEO)

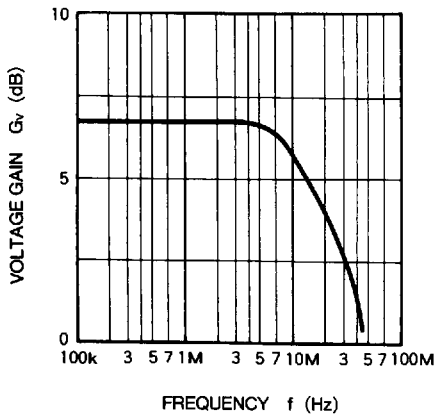

OUTPUT DC VOLTAGE VS. INPUT DC VOLTAGE (VIDEO)

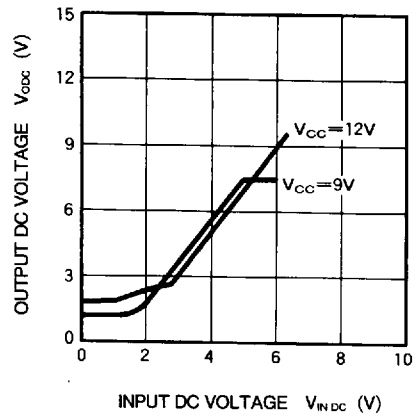

CROSSTALK VS. FREQUENCY (VIDEO)

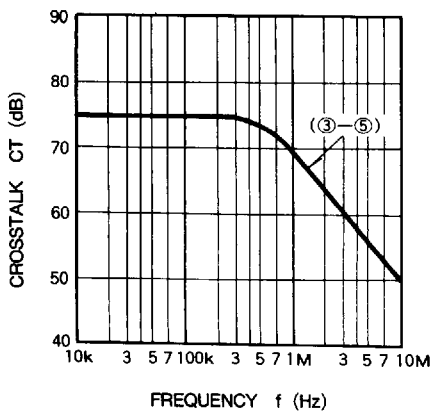

TOTAL HARMONIC DISTORTION VS. OUTPUT VOLTAGE (VIDEO)

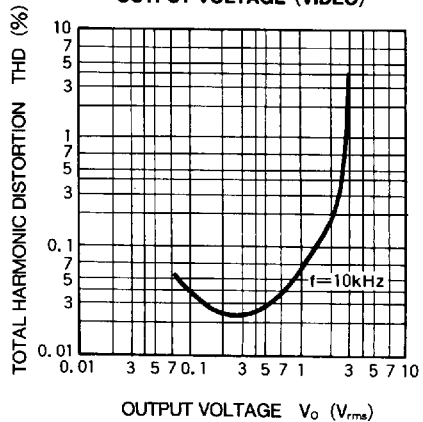

6249826 0021440 726

APPLICATION EXAMPLE

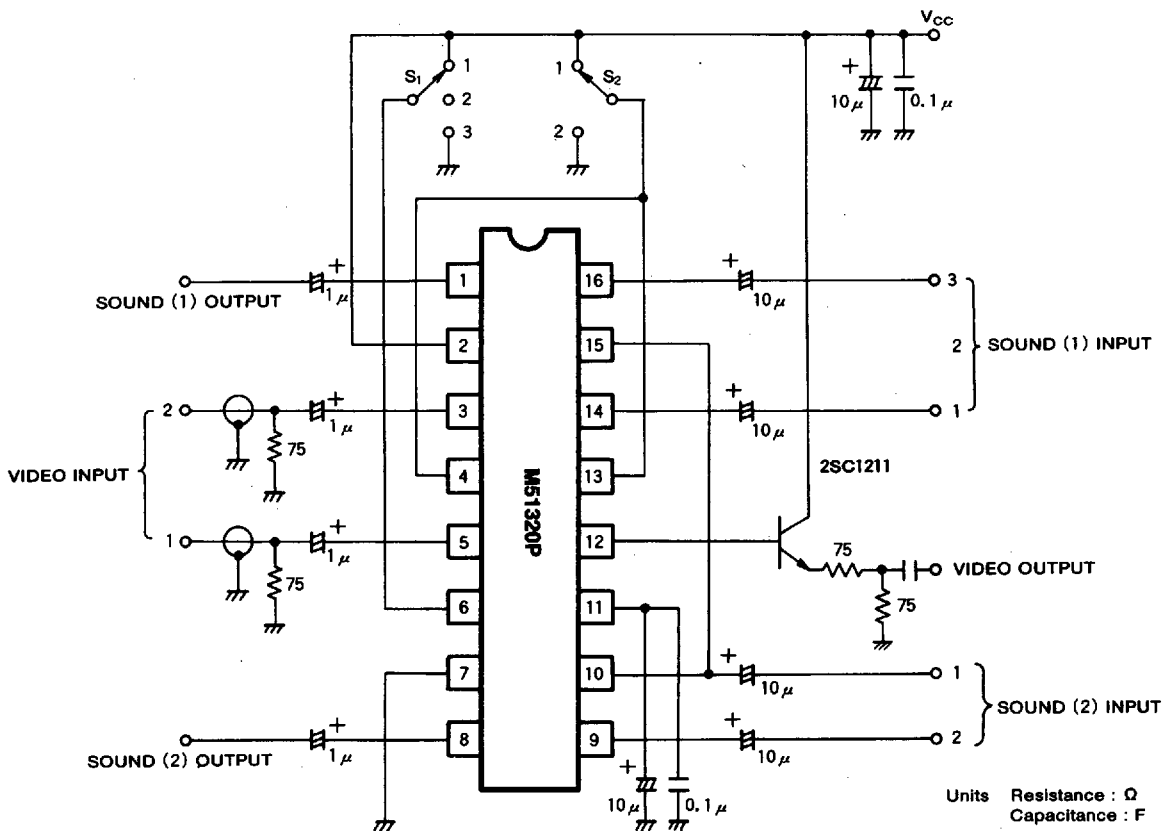

PRECAUTIONS FOR APPLICATION

When video output is sent through a 75Ω output and 12V supply is used, an external transistor buffer, such as the one shown in the above diagram, should be connected to maintain a balance with the power dissipation of the package. Should 9V be the sole supply voltage, a direct drive arrangement can be used as in the diagram at right by connecting resistor R_E between the output pin and ground. Since an emitter-follower output is used in video and sound outputs, when external wiring is long or a capacitive load is connected, a resistor with a value of several tens of ohms should be connected at a position near the output pin.

